



**TL 6420** 60cm Pull-out Hood with doble motor turbine and 3 speeds



LED

**DESCRIPTION**

60cm Pull-out Hood with doble motor turbine and 3 speeds

**LIFE STYLE**

Easy

**COLOURS**



**REFERENCE**

REF. 40474260  
EAN. 8421152146019

**FEATURES**

Pull-out hood  
Mechanical control panel  
3 speeds  
Exhaust capacities:  
Free Outlet, m<sup>3</sup>/h: 390  
Max., m<sup>3</sup>/h: 354  
Min., m<sup>3</sup>/h: 177  
Noise (LwA) Max Speed, dB: 69  
Noise (LwA) Min Speed, dB: 55  
2 Integrated halogen lamps  
2 aluminium filters  
Automatic Lighting  
Exchangeable Front Panel

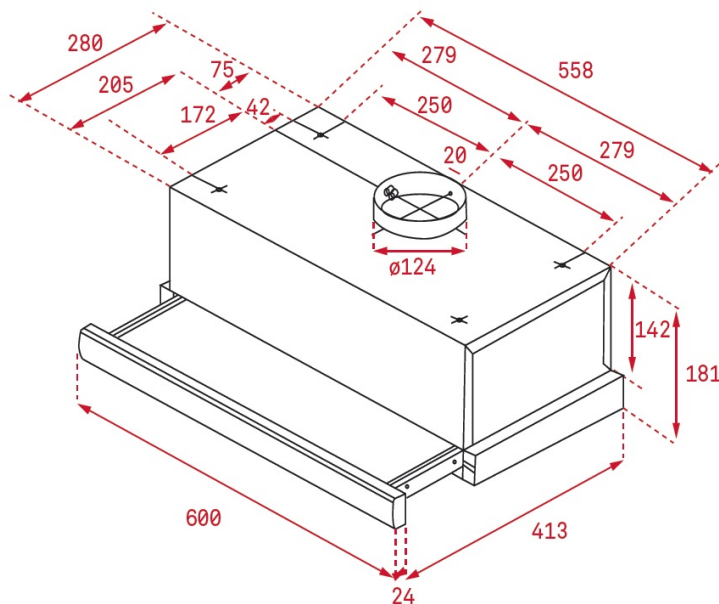

## DIMENSIONS

**Product height (mm):** 184

**Product width (mm):** 600

**Product depth (mm):** 288/413

**Product length (mm):**

**Net weight (Kg):** 7,92

## TECH SPECS

### PARTICULAR CHARACTERISTICS

**Certificates:** CE; CB; Rohs

**Ø Outlet (mm):** 120

**Type of inner light:** LED

**Inside light Consumption (W):** 6

**Plug type:** European plug

**Power rate (V):** 220-240

**Frequency (Hz):** 50-60

**Total hood power (W):** 192

**Number of motors:** 1

**Motor power (W):** 180

**EU REGULATION NO. 65/2014  
&66/2104**

**Annual energy consumption AEC kWh/annum (kWh):** 100

**Energy Efficiency Class:** D

**Fluid Dynamic Efficiency (FDEhood):** 9

**Fluid Dynamic Efficiency class:** E

**Light Efficiency (Lehood) lux/Watt:** 4,9

**Lighting Efficiency class:** F

**Grease Filtering Efficiency class:** D

**Air flow (Qmin) m<sup>3</sup>/h:** 181

**Air flow (Qmax):** 350  
**Noise (LwA) min. speed (dB):** 55  
**Noise (LwA) max. speed (dB):** 69  
**Energy Efficiency Index (EEI):** 97,3  
**Time increase factor:** 1,7  
**Air pressure at best efficiency point(Pbep) Pa:** 219  
**Electric power input at best efficiency point (Wbep) W:** 147  
**Nominal power of the lighting system (WL) W:** 12  
**Average illumination of the lighting system on the cooking surface (Emiddle) Lux:** 59

## ACCESSORIES

**Anti Return valve:** Yes  
**Outlet extension:** yes  
**Optional Charcoal Filter:** C1C  
**Conventional recirculation kit (opt) - w/tube cover:** No

## MODELS

**Number of filters:** 2  
**Filter description:** Aluminum  
**Control panel:** Mechanical  
**Number of speeds:** 3

## PRODUCT INFORMATION SHEET - DELEGATED REGULATION (EU) 65/2014

**Supplier name or trademark:** TEKA  
**Model identifier:** TL 6420  
**Annual Energy Consumption:** 100  
**Energy Efficiency Class:** D  
**Fluid Dynamic Efficiency:** 9  
**Fluid Dynamic Efficiency class:** E  
**Lighting Efficiency:** 4,9  
**Lighting Efficiency class:** F  
**Grease Filtering Efficiency class:** D  
**Air flow (min speed normal use):** 181  
**Air flow (max speed normal use):** 350  
**Air flow (intensive or boost use):** N/A  
**Airborne acoustical A-weighted sound power emissions (min speed normal use):** 55  
**Airborne acoustical A-weighted sound power emissions (max speed normal use):** 69  
**Power consumption in off mode (W):** N/A  
**Power consumption in standby mode (W):** N/A



TL 6420

ENERGY LABEL

